

Model GX Series

Triplex Plunger Pump
Operating Instructions/
Repair Instructions Manual

Consumer Pump

Horizontal/Vertical Pump
with built-in Thermal
Relief Valve and Siphon
Injector

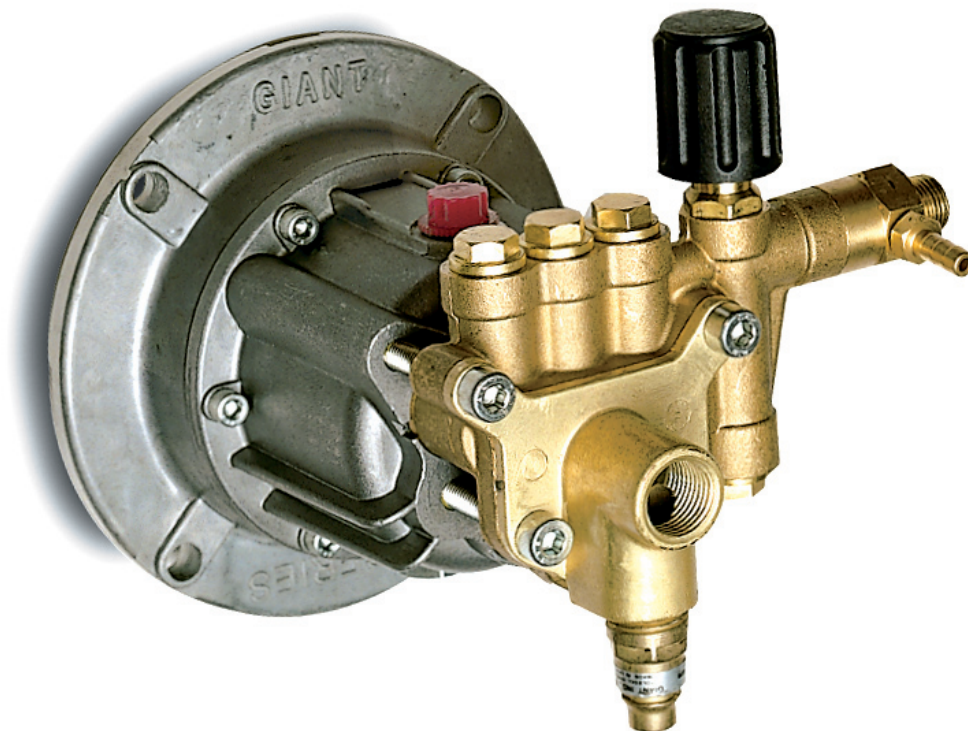

GIANT
Performance Under Pressure



Contents:

Installation Instructions:	page 2
Pump Specifications:	page 3
Exploded View/Kits:	page 4
Torque Specifications:	page 5
Repair Instructions:	pages 6-7
Dimensions:	back page
Warranty Information:	back page

Updated 12/16

INSTALLATION INSTRUCTIONS

Installation of the Giant Industries, Inc., pump is not a complicated procedure, but there are some basic steps common to all pumps. The following information is to be considered as a general outline for installation. If you have unique requirements, please contact Giant Industries, Inc. or your local distributor for assistance.

1. The pump should be installed flat on a base to a maximum of a 15 degree angle of inclination to ensure optimum lubrication.
2. The inlet to the pump should be sized for the flow rate of the pump with no unnecessary restrictions that can cause cavitation. Teflon tape should be used to seal all joints. Maximum inlet fluid temperature is 80°F.
3. The discharge plumbing from the pump should be properly sized to the flow rate to prevent line pressure loss to the work area. It is essential to provide a safety bypass valve between the pump and the work area to protect the pump from pressure spikes in the event of a blockage or the use of a shut-off gun.

4. Use of a dampener is necessary to minimize pulsation at drive elements, plumbing, connections, and other system areas. The use of a dampener with Giant Industries, Inc. pumps is optional, although recommended by Giant Industries, Inc. to further reduce system pulsation. Dampeners can also reduce the severity of pressure spikes that occur in systems using a shut-off gun. A dampener must be positioned downstream from the unloader.

6. Before beginning operation of your pumping system, remember: Check that the crankcase and seal areas have been properly lubricated per recommended schedules. Do not run the pump dry for extended periods of time. Cavitation will result in severe damage. Always remember to check that all plumbing valves are open and that pumped media can flow freely to the inlet of the pump.

Finally, remember that high pressure operation in a pump system has many advantages. But, if it is used carelessly and without regard to its potential hazard, it can cause serious injury.

IMPORTANT OPERATING CONDITIONS

Failure to comply with any of these conditions invalidates the warranty.

1. Prior to initial operation, Check for proper oil level. DO NOT OVERFILL.

**Use Giant Oil - P/N 01153
(20W-50 Synthetic)**

Crankcase oil should be changed after the first 50 hours of operation, then at regular intervals of 200 hours or less depending on operating conditions.

Since it is difficult to determine the oil level in the pump, check for signs of oil leakage around the pump before and during operation. The best areas to check are between the manifold and the crankcase and between the adapting plate and the engine / motor mounting surface. Lastly, you can see if there is any leakage around the vent cap (on the top of the pump).

If everything looks okay, continue to use the pump. At least once per year (or every 200 hours), remove the oil from the pump and replace with the required amount of oil. (See page 3)

2. Pump operation must not exceed rated pressure, volume, or RPM. A pressure relief device must be installed in the discharge of the system.

3. Acids, alkalines, or abrasive fluids cannot be pumped unless approval in writing is obtained before operation from Giant Industries, Inc.

4. Run the pump dry approximately 10 seconds to drain the water before exposure to freezing temperatures.

NOTE: Contact Giant Industries for Service School Information. Phone: (419)-531-4600

Specifications Model GX Series

	U.S.	(Metric)
Flow	2.5 GPM	(9.5 LPM)
Maximum Discharge Pressure.....	2500 PSI	(172 bar)
Maximum Inlet Pressure	Up to 90 PSIG ¹	6.2 Bar ¹
Pump Speed		3450 RPM
Plunger Diameter.....	4.23"	16mm
Stroke		5.1mm (7.1° angle)
Crankcase Oil Capacity (Horizontal).....	4.1 fl.oz.....	(121 ml)
Crankcase Oil Capacity (Vertical).....	4.7 fl. oz.	(138 ml)
Temperature of Pumped Fluids.....	Up to 80 °F	(27 °C)
Inlet Port		1/2" NPT
Discharge Port.....		3/8" NPT
Shaft Rotation		Either Direction ²
Weight.....	9 lbs.	(4.1 Kg)
Width.....	8.325"	(21.15cm)
Height	6.45"	(16.4cm)
Swash Plate Bore (Horizontal).....		3/4" x 3/16" Keyway
Swash Plate Bore (Vertical).....		7/8" x 3/16" Keyway
Valve Type		Polyamide Plastic

¹ A 25 PSIG (2 Bar) minimum inlet pressure is **required**.

² The pump itself can be driven in either direction of rotation; however, the cooling fan on TEFC motors must always be positioned so that the cooling air is drawn from the non-drive end of the motor towards the pump.

GX2525 ELECTRIC HORSEPOWER REQUIREMENTS					
RPM	GPM	1000 PSI	1500 PSI	2000 PSI	2500 PSI
3450	2.5	1.7	2.6	3.4	4.3

HORSEPOWER RATINGS:

The rating shown are the power requirements for the pump. Gas engine power outputs must be approximately twice the pump power requirements shown above.

GX2525 GAS HORSEPOWER REQUIREMENTS					
RPM	GPM	1000 PSI	1500 PSI	2000 PSI	2500 PSI
3450	2.5	2.3	3.4	4.5	5.7

We recommend a 1.15 service factor be specified when selecting an electric motor as the power source. To compute specific pump horsepower requirements, use the following formula:

$$\text{Electric HP} = (\text{GPM} \times \text{PSI}) / 1450$$

$$\text{Gasoline HP} = (\text{GPM} \times \text{PSI}) / 1100$$

GX SERIES PARTS LIST

ITEM#	Part#	Description	QTY.	ITEM#	Part#	Description	QTY.
1	07805	Radial Shaft Seal	1	29	06227	8mm Ball	1
2	06310A	Adapting Flange	1	30	07917A	Washer	1
3	06294	O-Ring (86 x 2.5mm)	1	31	07918A	Adjusting Spring	1
4	06300	Rear Bearing	1	32	07919	Pressure Spring	1
5	06326	Wobble plate 7.1 degree horizontal, 3/4"	1	33***	06524	Adjusting Screw	1
5	06331	Wobble plate 7.1 degree vertical, 7/8"	1	34***	06324	Adjusting Screw Plug	1
5	06419	Two-piece wobble plate, 7.1 degree,(GXH2525A only)	1	35	06286	Manifold	1
5A	06159	Steel Shaft (for 06419)	1	36	06295	Discharge Valve Cone	3
6	06301	Front Bearing	1	38	07910A	Triangle O-Ring	1
7	06289	Spring Disk	3	39	06298	Suction Flange	1
8	06287	16mm Plunger	3	40	06302	Stud Bolt(M8x1.25x50mm)	4
9	06288	Plunger Spring	3	41****	12326	Kick Back O-Ring	1
10	06299	Socket Bolt (1/4-20x3/4 10.9 GRD)	6	42****	12325	Kick Back Valve Cone	1
11	08192	Gasket	1	43****	12328	Kick Back Spring	1
12	06273	Oil Drain Plug	1	44 ^A	06727	Orifice, 1.8mm	1
13	06282	Crankcase	1	44 ^A	06339	Orifice, 2.1mm	1
14	08083	Vent Cap, (Horizontal Only)	1	44 ^A	06340	Orifice, 2.3mm	1
15	06316	16mm Oil Seal	3	45	06312	O-Ring in Nozzle	1
17	06292	Spacer	3	46	07913	O-Ring	1
18	07374	Valve Spring	6	47****	06303	Injector Retainer	1
19	06267	Guided P-Valve	3	48	23009	Spring	1
20	06290	Pressure Ring	3	49	23010-0100	Ball	1
21	06315	16mm V-Sleeve	3	50	12516-0001	O-Ring	1
22	06296	Discharge Plug	4	51	12517	Hose Barb	1
23***	12007	O-Ring	5	52	07939	Nut	1
24	06304	Piston	1	53	07044	Locknut	1
25	12031-0002	Back-up ring	2	54	07045	Handwheel	1
26***	07937	O-Ring	2	55	07068	Locking Nut W/Nylon Insert	1
27	08638	O-Ring of Push Seat	1	56	07046	Cover	1
28	06256	Push in Seat	1	75	23422A	Thermal Relief Valve (Horizontal Pumps)	1
				75	23422A-N	Thermal Relief Valve (Vertical Pumps)	1

^A = See pump numbering system on page 7.

* When ordering 06310A, please order 17026A which includes 06300, 07805, and 06294

** When ordering 06331, please order 17032 which includes 06331, 06301, and shaft ring.

*** Optional Non-Handle Model - (Item 23) o-ring p/n 12007, (Item 26) o-ring p/n 07937, (item 33) adjusting screw p/n 06323, (item 34) adjusting screw plug p/n 06324

**** Optional Non-Injector Model - (item 41) kick back valve o-ring p/n 12326, (item 42) kick back valve cone p/n 12325 (item 43) kick back spring p/n 12328, (item 47) kick back valve retainer p/n 12340

+ When ordering 06326, please order 17020 which includes 06326, 06301, and shaft ring.

++ When ordering 06419, please order 17171 which includes 06419, 06159, and 06301.

MOUNTING ACCESSORIES (Sold Separately)

Item	Description
09103(EX) ¹	Gasoline Flange Kit (excluding GXH2525A models)
09605	Gasoline Flange Kit (GXH2525A only)
07435	Bolts for 09103/09605

¹ "EX" Suffix added for engines requiring an external pilot

GX SERIES TORQUE SPECIFICATIONS

Position	Item#	Description	Torque Amount (ft.-lbs)
10	06299	Socket Bolt	100 in.-lbs.
40	06302	Stud Bolt	150 in.-lbs.

GX Series EXPLODED VIEW

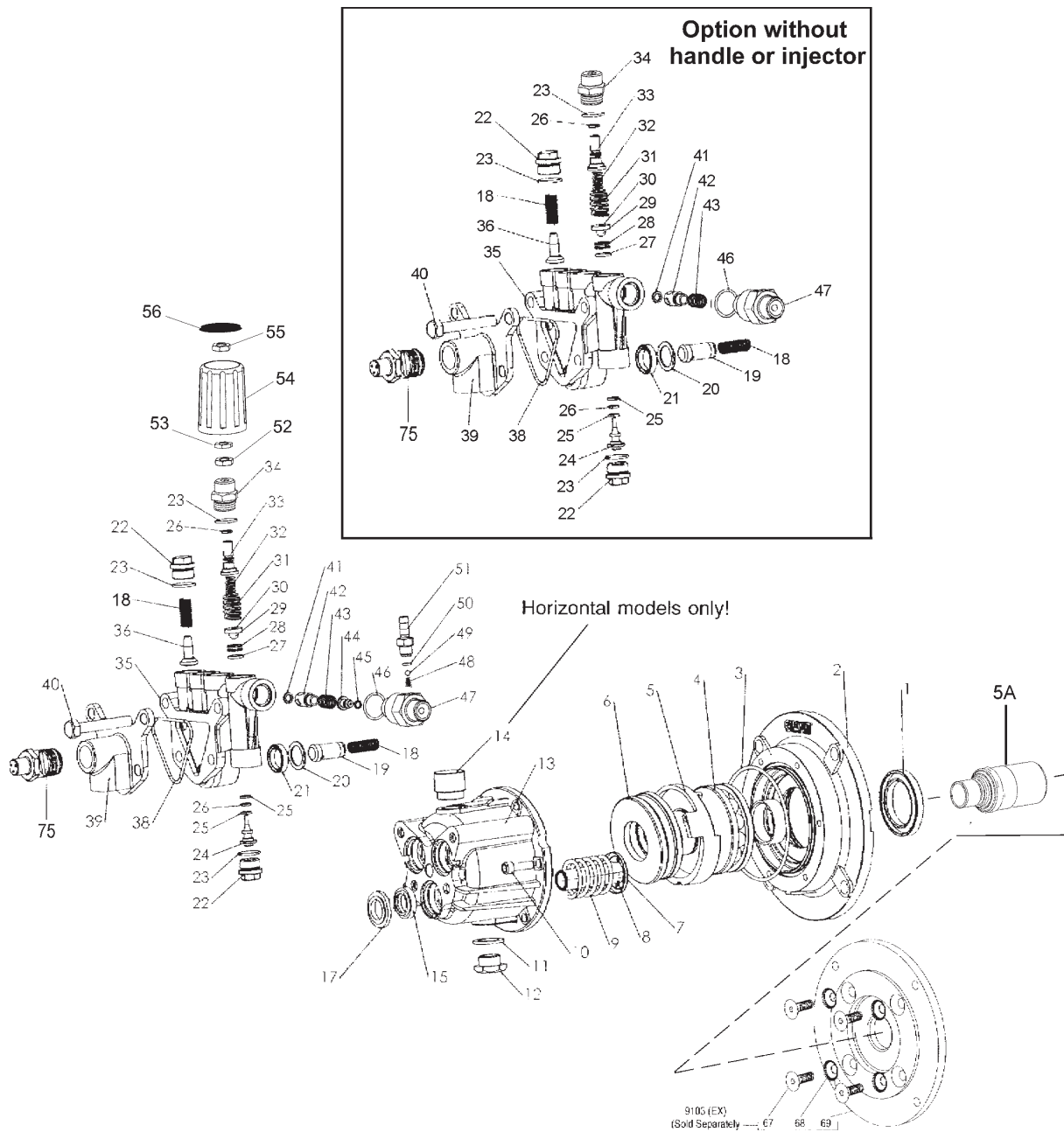

Plunger Packing Kit # 09465

Item	Part #	Description	Qty.
20	06290	Support Ring	3
21	06315	V-Sleeve	3

Oil Seal Kit # 09468

Item	Part #	Description	Qty.
15	06316	Plunger Oil Seal	3

Valve Assembly Kit # 09466

Item	Part #	Description	Qty.
18	07374	Valve Spring	6
19	06267	Guided P-Valve	3
36	06295	Discharge Valve Cone	3

Unloader Repair Kit # 09467

Item	Part #	Description	Qty.
23	12007	O-Ring	2
25	12031-0002	Back-up Ring	2
26	07937	O-Ring	2
27	08638	O-Ring	1
28	06256	Seat	1
29	06227	8mm Ball	1
41	12326	O-Ring	1

REPAIR INSTRUCTIONS - GX SERIES

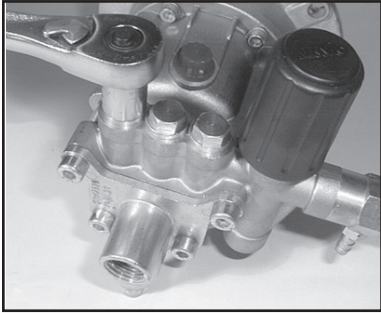

1. With a 14mm socket wrench, remove the three discharge valve plugs (22). Inspect the valve plug o-rings (23) for wear, and replace as necessary.

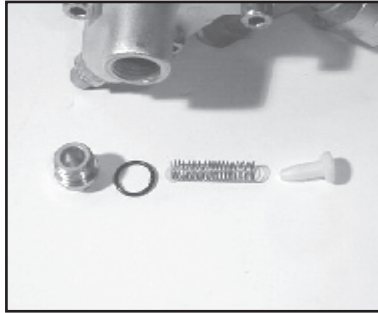

2. Remove the valve spring (18) and valve cone (36) from the manifold (35). Inspect the parts for wear and replace as necessary.



3. With a crescent wrench, remove the kickback valve spring retainer (47). Inspect the o-ring (46) for wear and replace as necessary. Remove the kickback valve spring (43), kickback valve cone (42), and the o-ring (41) from the manifold (35). Inspect the parts for wear and replace as necessary.

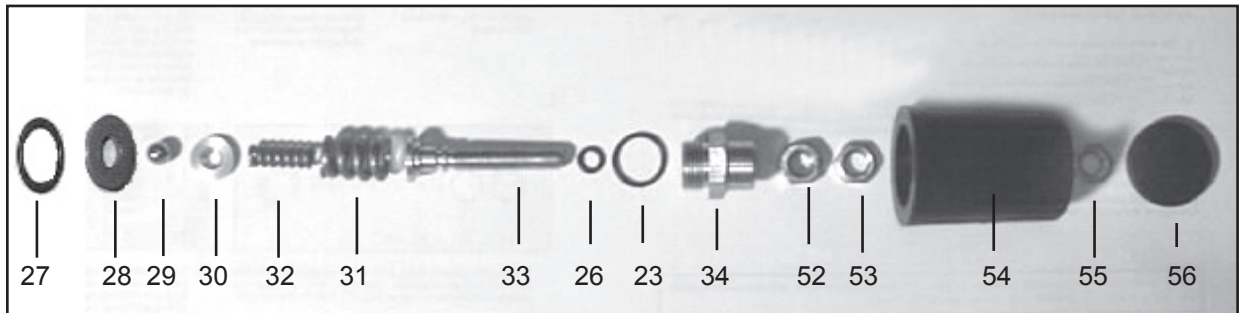

4. With a 19mm wrench, remove the adjusting screw plug (34). Unscrew the adjusting screw (33) from the adjusting screw plug (34). Inspect the o-rings (23 & 26) for wear and replace as necessary.

5. Remove the adjusting spring (31), pressure spring (32), washer (30) and by pass valve ball (29) from the manifold (35). Inspect the parts for wear and replace as necessary.

Optional pump without handle - exclude items (52, 53, 54, 55, 56).

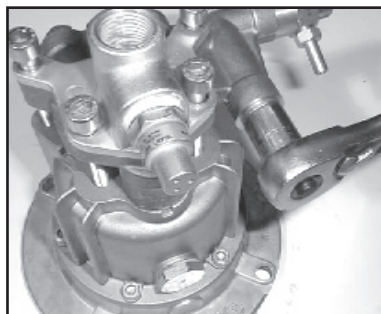

6. With a 14mm socket wrench, remove the guide plug (22) and o-ring (23).

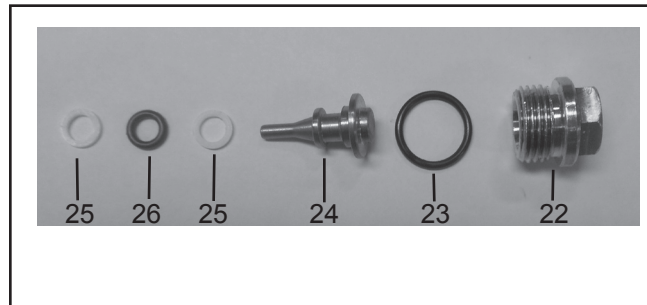

7. Remove the piston (24), o-ring (26), and backup rings (25). Remove the bypass valve seat (28). Inspect the parts for wear and replace as necessary. **IMPORTANT! Make sure that the shoulder on bypass valve seat (28) is facing the discharge plug (22).**

GX2525 EXPLODED VIEW

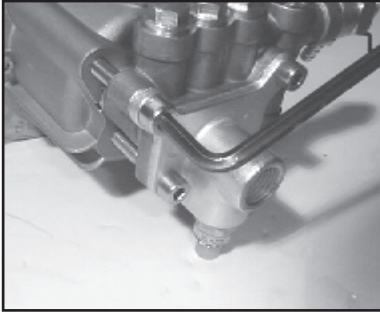

8. Next, remove the four manifold bolts (40) with a 6mm allen wrench.

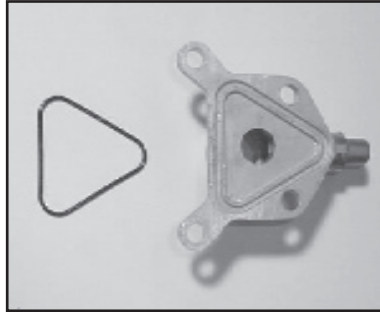

9. Remove the suction flange (39) and flange o-ring (38). Inspect the o-ring for wear and replace as necessary.

10. Tap the back of the manifold (35) with a rubber mallet to dislodge, and slide off the plungers. (8). Take note of the position of the discharge port so as to place the manifold in the same position during reassembly.

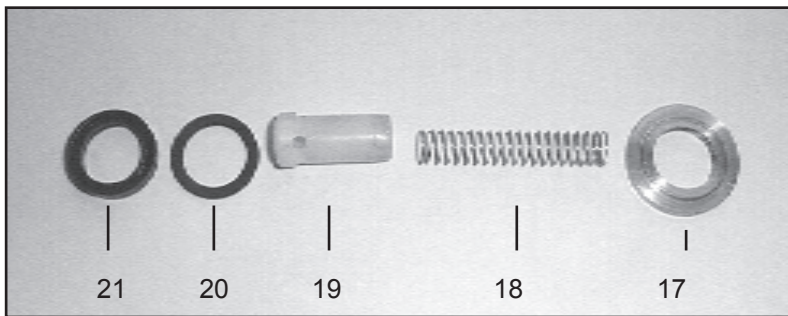

11. Remove the guided p-valve, (19), valve springs (18), v-sleeves (21) and pressure rings (20). Inspect for wear and replace as necessary. Remove the spacer ring (17) from the plungers (8).

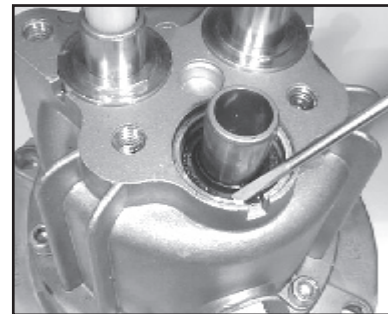

12. If the crankcase oil seals (15) are to be replaced, they can be removed by prying loose with a screwdriver. Take care not to make contact with the plunger (8) and pry out the oil seals from their housing. Seals should not be reinstalled until after step #13.

13. Reassemble in reverse order. Fill the crankcase with the proper amount of oil (see specifications page 3). The pump is now ready for operation.

GX and HR Pump Part Numbering System

GX or HR Series	Flow	Pressure (in 100 psi increments)		Injector Size	Thermal Relief Valve	Wobble Plate Shaft Bore
Vertical	20=GPM	25=2500 PSI		1=2.1 mm	1=1/2"	2=7/8"
Horizontal	23=GPM			2=1.8mm		1=3/4"
	25=GPM			3=2.3mm		3=1"
						4=5/8"
GX or HR	2.5	25	-	1	1	1

For example, a GXV2525-112 is a GX pump that produces 2.5 GPM @ 2500 PSI, has a injector with a 2.1mm Oriface, 1/2" thermal relief valve and 7/8" wobble plate bore.

GX Series Dimensions inches (mm)

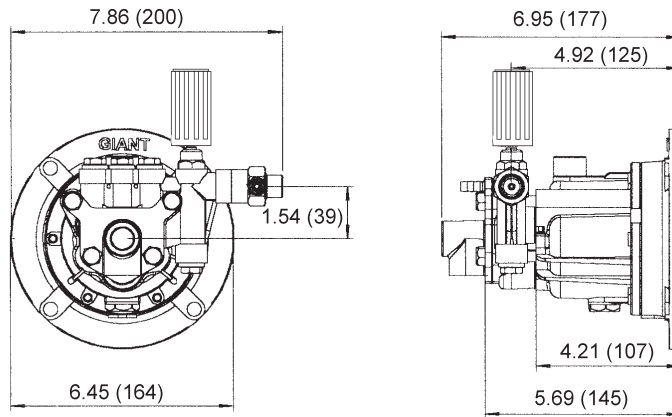

GIANT INDUSTRIES LIMITED WARRANTY

Giant Industries, Inc. pumps and accessories are warranted by the manufacturer to be free from defects in workmanship and material as follows:

1. For portable pressure washers and self-service car wash applications, the discharge manifolds are guaranteed for the life of the pump. Our other pump parts, used in portable pressure washers and in car wash applications, are warranted for five years from the date of shipment for all pumps used in NON-SALINE, clean water applications.
2. One (1) year from the date of shipment for all other Giant industrial and consumer pumps.
3. Six (6) months from the date of shipment for all rebuilt pumps.
4. Ninety (90) days from the date of shipment for all Giant accessories.

This warranty is limited to repair or replacement of pumps and accessories of which the manufacturer's evaluation shows were defective at the time of shipment by the manufacturer. The following items are NOT covered or will void the warranty:

1. Defects caused by negligence or fault of the buyer or third party.
2. Normal wear and tear to standard wear parts.
3. Use of repair parts other than those manufactured or authorized by Giant.
4. Improper use of the product as a component part.
5. Changes or modifications made by the customer or third party.
6. The operation of pumps and or accessories exceeding the specifications set forth in the Operations Manuals provided by Giant Industries, Inc.

Liability under this warranty is on all non-wear parts and limited to the replacement or repair of those products returned freight prepaid to Giant Industries which are deemed to be defective due to workmanship or failure of material. A Returned Goods Authorization (R.G.A.) number and completed warranty evaluation form is required prior to the return to Giant Industries of all products under warranty consideration. Call (419)-531-4600 or fax (419)-531-6836 to obtain an R.G.A. number.

Repair or replacement of defective products as provided is the sole and exclusive remedy provided hereunder and the MANUFACTURER SHALL NOT BE LIABLE FOR FURTHER LOSS, DAMAGES, OR EXPENSES, INCLUDING INCIDENTAL AND CONSEQUENTIAL DAMAGES DIRECTLY OR INDIRECTLY ARISING FROM THE SALE OR USE OF THIS PRODUCT.

THE LIMITED WARRANTY SET FORTH HEREIN IS IN LIEU OF ALL OTHER WARRANTIES OR REPRESENTATION, EXPRESS OR IMPLIED, INCLUDING WITHOUT LIMITATION ANY WARRANTIES OR MERCHANTABILITY OR FITNESS FOR A PARTICULAR PURPOSE AND ALL SUCH WARRANTIES ARE HEREBY DISCLAIMED AND EXCLUDED BY THE MANUFACTURER.



GIANT INDUSTRIES, INC., 900 N. Westwood Ave., Toledo, Ohio 43607
PHONE (419) 531-4600, FAX (419) 531-6836, www.giantpumps.com
© Copyright 2016 Giant Industries, Inc.